



# ALTERNATOR VOLTAGE REGULATOR SPS - 341 FOR PMG TYPE ALTERNATOR

**WARNING:** To prevent personal Injury or equipment damage only qualified technician / operator should install, operate or service this device

**CAUTION:** While using meager & high potential equipment, disconnect all connections of AVR. Incorrect use of such equipments could damage components of AVR

info@spsindia.biz

## CONNECTION DIAGRAM OF AVR TO TYPICAL ALTERNATOR WITH PMG EXCITATION SYSTEM

**Note:** All potentiometers are 25 turns type to complete its start to end rotation

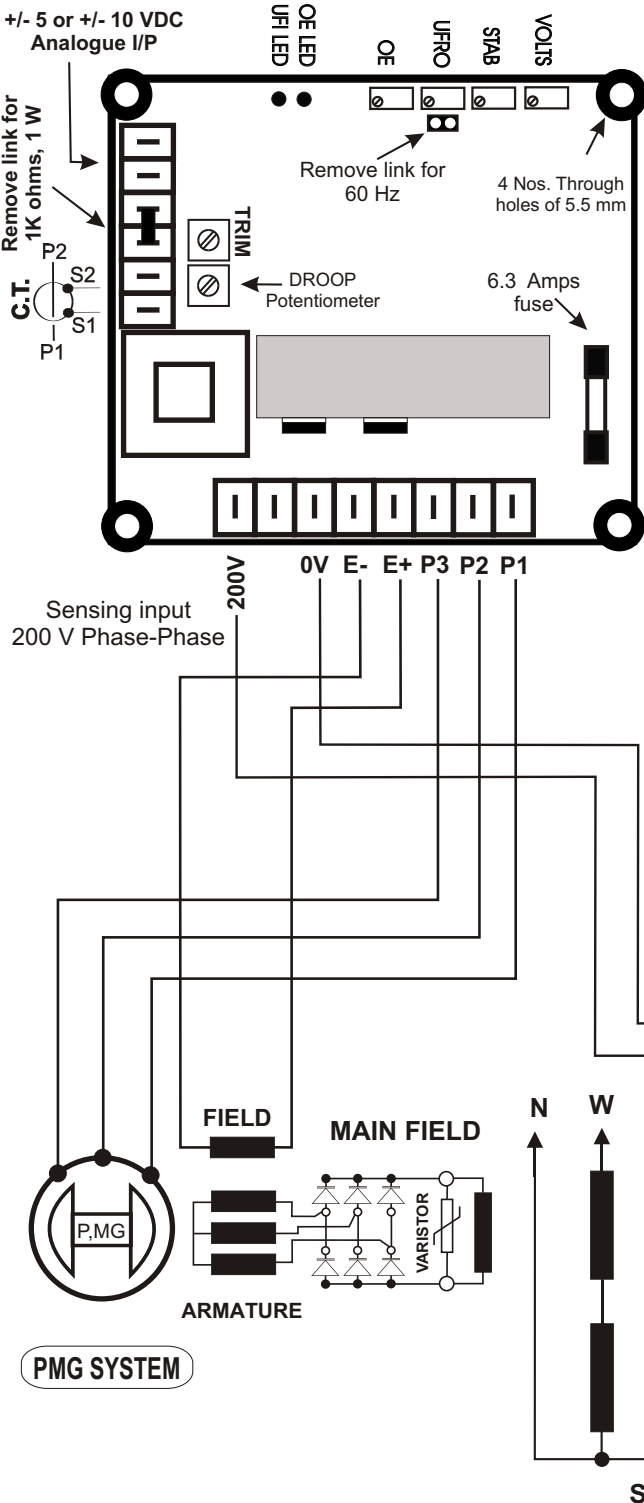

### VOLTS:

Rotate these pot clockwise to increase AC terminal voltage and anticlockwise to decrease AC terminal voltage. If it is required to adjust voltage from remote location then a 1 K/1 W potentiometer can be connected on its specified terminal and voltage can be varied in the range of +/- 5 %.

### STAB:

Stability potentiometer is factory set such that optimum response of voltage recovery is achieved during sudden load changes. In some cases in order to release burden on engine it is required to sluggish the recovery time of voltage, therefore to increase the response time STAB potentiometer is carefully rotated anti clock wise direction such that response time will increase resulting in larger dip of terminal voltage during sudden load. Kindly note that by excessively rotating STAB potentiometer to clock wise direction at one stage will cause voltage fluctuation. Again by gradually rotating the STAB pot to anti clock wise direction will stabilize the generator voltage. (It is advisable that only technically qualified person should adjust these pot.)

### UFRO:

The under frequency roll off ( UFRO ) is factory set at 47 Hz for 50 Hz generator. For 60 Hz generator remove link to set kee point to 57 Hz. It is possible to set UFRO potentiometer from 45 Hz to 59 Hz. rotating UFRO potentiometer clock wise direction will set UFRO level in increasing frequency direction and rotating in anti clock wise direction will set to decreasing frequency. UFRO activation is indicated by UFI LED.

### OE:

Excitation field current exceeding its specified limit indirectly indicates alternator over load. AVR has in built accurate current sensing circuitry to protect alternator windings from over load. DC field current monitored by AVR circuitry will cut off field supply after 20-25 seconds when field current exceeds preset value. The over excitation trip level is factory set to 6 ADC. It will be required to set trip level as specified by excitation current on alternator name plate. The OE potentiometer is factory set to fully clock wise direction ( 6 A DC). By rotating the potentiometer to anti clock wise direction will set DC current trip level from 6 A DC downwards to 0 A DC. Vice versa rotating OE potentiometer to clock wise direction will set trip level from 0 A DC upwards to 6 A DC There are two methods to set trip l evel. First method is to load the generator to full load and then rotate OE potentiometer anti clock wise direction till OE LED turns ON. Once OE LED turns ON the timer will be activated and after 20-25 seconds field supply will be cut off. Second method is to connect a DC ampere meter in between F1 & field wire, now load the generator such that required DC current is observed on ampere meter. Rotate OE potentiometer anti clock wise direction such that OE LED turns ON and this will set OE trip at required DC current.

### DROOP:

If it is required to synchronize more than one generator, so that system capacity can be increased, it is necessary that power sharing between all generators is equal. Quadrature droop method is used to control reactive current of generators. A current transformer with secondary current of 0.22 A at full load of generator is connected third phase of generator which is not used for sensing of AVR. The direction of secondary current should be such that droop characteristics is achieved. DROOP characteristics of +/- 5 % can be achieved at 0.22 Ampere.

### TRIM ( A1 & A2 ):

An analogue signal of +/- 5VDC or +/-10 VDC can be applied to A1 & A2 terminal to control PF / voltage of generator. An internal TRIM potentiometer is used to adjust the percentage of analogue signal feeding to control circuit..

## SPECIFICATIONS:

INPUT VOLTAGE	200 VAC / 400 Hz max..
SENSING VOLTAGE	180 to 265 V AC, 50/60 Hz
OUTPUT EXCI. VOLTAGE	180 V DC
OUTPUT EXCI. CURRENT	6 A DC. ( 15 A DC FOR 15 - SECONDS )
INPUT FREQUENCY	50 / 60 Hz link select
RESIDUAL BUILD UP	6 V AC AT 50 / 60 Hz.
VOLTAGE REGULATION	+/- 1 %, thermal drift 0.04% per 1 Deg. C
UNDER FREQUENCY (UFRO / UFI LED)	FACTORY SETTING 47 Hz, REMOVE LINK FOR 60 Hz. INDICATION BY UFI - LED
OVER EXCITATION CURRENT TRIP ( O/E ) (Please rotate OE pot in anti-clockwise direction to set excitation current tripping level below 6 A DC)	25 SECONDS DELAY TIMER. ADJUSTABLE POT RANGE 0 - 6 ADC. INDICATION BY OE - LED
EXTERNAL POTENTIOMETER	+/- 5 % using 1 K Ohms pot
VIBRATION	20-100Hz 50 mm/sec 100Hz - 2 KHz 3.3g
OPERATING TEMPERATURE	-40 TO +70 °C
STORAGE TEMPERATURE	-55 TO +80 °C
RELATIVE HUMIDITY	0 TO +70 °C : 95 %
FUSE ( FAST ACTING)	6.3 AMPS ( SIZE: 5 X 20 mm)
DIMENSIONS ( L X B X H)	125 X 110 X 58 mm
WEIGHT	465 gm

**NOTE:** Continuous development of our products entitles us to change specifications & other details without notice. Please contact factory for latest information ( info@spsindia.biz )