

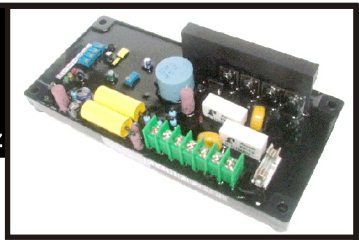

# SPECIFICATIONS & TECHNICAL DETAILS OF AVR SPS - 3806

info@spsindia.biz



### STAB:

If there is AC terminal voltage hunting than slowly rotate STAB pot anticlockwise to stabilize the voltage. Do not excessively rotate anticlockwise other wise response time will increase resulting larger dip in terminal voltage during sudden load. Excessively rotating the STAB pot in clockwise direction will result in voltage hunting.  
(It is advisable that only technically qualified person should adjust these pot.)

### UFRO:

It is not required to adjust these pot as it is factory set at 47 Hz. If it is required to adjust than by rotating the pot to clockwise will increase UFRO level above 47 Hz and rotating anticlockwise will decrease UFRO level below 47 Hz. UFRO activation is indicated by UFI LED.

### OE:

Field current over excitation set pot is factory set to maximum clockwise (6 Amps). If it is required to cut off excitation current below 6 Amps, than connect DC ampere meter in series with F1. Load the alternator such that required DC current is noted on ampere meter. Now rotate OE pot anticlockwise till OEI LED is just ON. Once LED is turned ON the internal timer will be activated and will cut off excitation Power.

### VOLTS:

Rotate these pot clockwise to increase AC terminal voltage and anticlockwise to decrease AC terminal voltage

UFI: Under frequency activation indicator LED

OEI: Over excitation current trip indicator LED

50Hz: LED turns ON indicating frequency above 50 Hz.

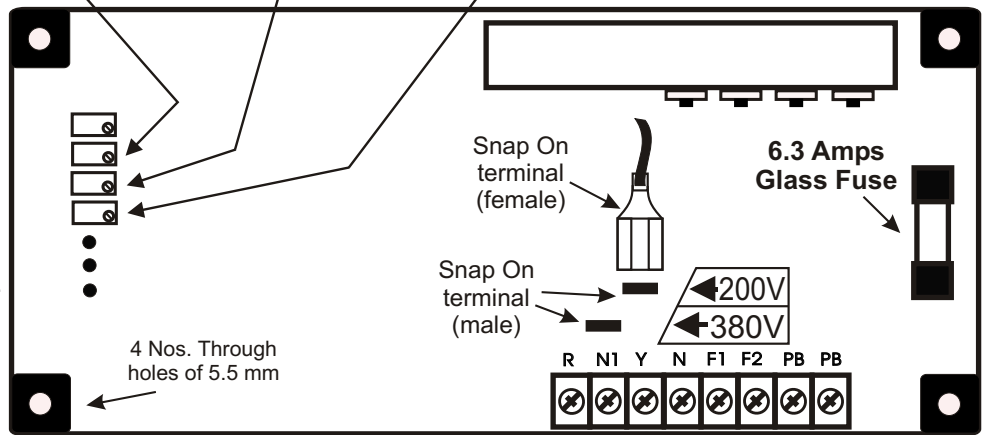

#### For 3 Phase Alternator:

- 1) Terminal N1 to be kept open
- 2) In order to get 380 V DC output, link "snap on" terminal to 380V
- 3) In order to get 200 V DC output link "snap on" terminal to 200V

#### For 1 Phase Alternator:

- 1) Link terminal N & N1. R to be kept open.
- 2) Connect "snap on" terminal to 200V. DC output available will be 200 V DC.
- 3) If "snap on" terminal connected to 380V than DC output will be zero volt..

## SPECIFICATIONS:

INPUT VOLTAGE	2 Phase(415V)+ Neutral for 3 phase alternator 1 Phase(220V)+ Neutral for 1 Phase alternator
SENSING VOLTAGE	415 V for three phase alternator 220 V for single phase alternator.
OUTPUT EXCI. VOLTAGE	(1) for 3 Phase alternator - 380 V DC when "snap on" terminal connected to 380V & 200VDC when "snap on" terminal connected to 200V. Terminal N1 kept open. (2) For single phase alternator 200VDC when "snap on" terminal connected 200V, N & N1 linked. Input terminal R to be kept open
OUTPUT EXCI. CURRENT	6 A DC. ( 10 A DC FOR 15 SECONDS )
INPUT FREQUENCY	50/60 Hz
RESIDUAL BUILD UP	5 V AC AT 50 Hz.
VOLTAGE REGULATION	+ / - 1 %
UNDER FREQUENCY (UFRO / UFI)	FACTORY SETTING 47 Hz, ADJUSTABLE POT. INDICATION BY UFI - LED
OVER EXCITATION CURRENT TRIP ( OE / OEI ) (Please rotate OE pot in anticlockwise direction to set excitation current tripping level below 6 A DC)	25 SECONDS DELAY TIMER. ADJUSTABLE POT RANGE 0 - 6 ADC. INDICATION BY OEI - LED (Factory setting 6 A DC max)
PUSH BUTTON PB / PB	PUSH TO DEVELOP VOLTAGE
50 Hz INDICATOR	GREEN LED TURNS ON WHEN FREQUENCY REACHES 50 Hz
GLASS FUSE( FAST ACTING)	6.3 AMPS (size: 5 X 20 mm)
DIMENSIONS (L X B X H)	200 X 95 X 50 mm
WEIGHT	450 gms

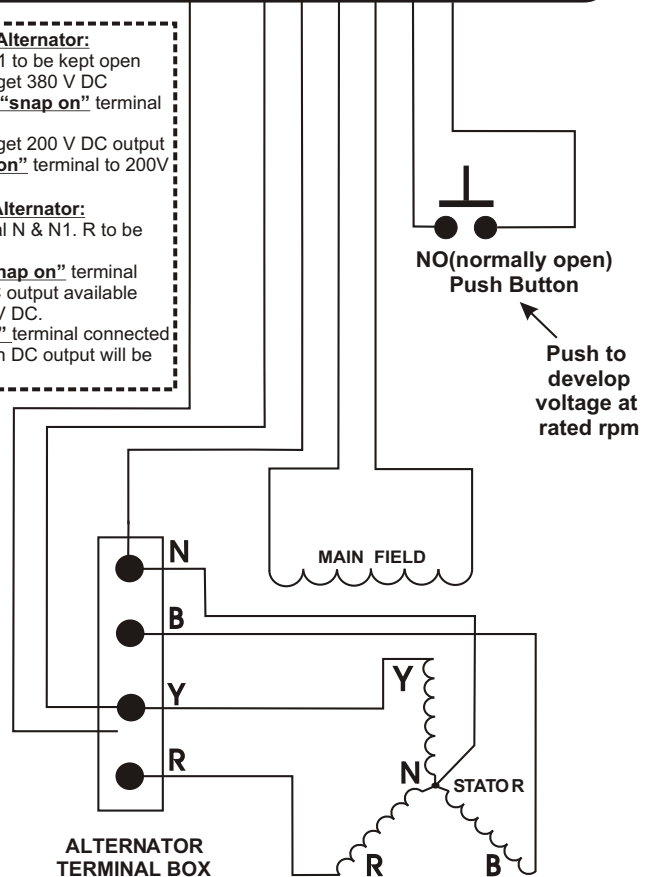

NOTE: Continuous development of our products entitles us to change specifications & other details without notice. Please contact factory for latest information ( info@spsindia.biz )